



ROYAL “OIL COUNTRY” BIG-BORE BULL HEAD LIVE CENTERS

The major and minor diameters of each head extend above and below nominal sizing – enabling each head to **cover a wider range of workpieces.**

Large capacity modular heads securely locate on a precision tapered shaft for maximum accuracy and rigidity.

± 0.00025 " TIR guaranteed.

Head angle is $60^{\circ} \pm \frac{15}{16}$ for proper part engagement.

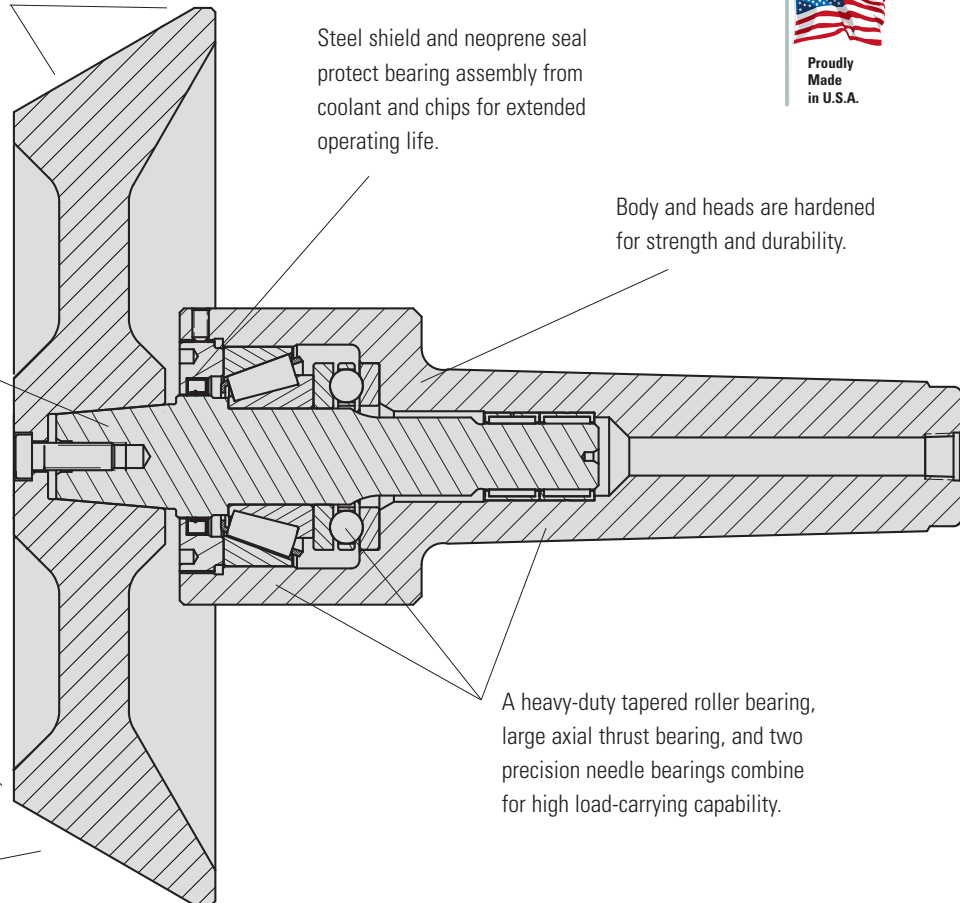

Steel shield and neoprene seal protect bearing assembly from coolant and chips for extended operating life.

Body and heads are hardened for strength and durability.

A heavy-duty tapered roller bearing, large axial thrust bearing, and two precision needle bearings combine for high load-carrying capability.



- ❑ Designed **specifically for machining large diameter pipes for the oil and gas industry**, but suitable for all large-bore applications.
- ❑ In contrast to standard bull head live centers, the modular head design of Royal “Oil Country” Big-Bore centers positions the workpiece closer to the bearing assembly for greater rigidity and longer operating life.
- ❑ Interchangeable **heads are relieved to achieve the optimal strength/mass ratio**, and are sized to cover a wider range of bore sizes with fewer models.
- ❑ Bearing configuration consisting of a heavy-duty tapered roller bearing, a large axial thrust bearing, and two precision needle bearings provides exceptional accuracy and rigidity under the most demanding production conditions.

ROYAL "OIL COUNTRY" BIG-BORE BULL HEAD LIVE CENTERS



Specifications

TAPER	HEAD PART NUMBER	B	G	J	MAX SUGGESTED RPM*	WEIGHT OF WORKPIECE (LBS.)	THRUST LOAD (LBS.)
5 MT	10791	4.62	1.63	5.31	2,050	4,500	2,650
5 MT	10792	7.37	4.38	4.59	1,300	4,500	2,650
5 MT	10793	10.12	7.13	4.59	950	4,500	2,650
5 MT	10794	12.87	9.88	4.59	750	4,500	2,650
5 MT	10795	15.62	12.63	4.59	600	4,500	2,650

TAPER	HEAD PART NUMBER	B	G	J	MAX SUGGESTED RPM*	WEIGHT OF WORKPIECE (LBS.)	THRUST LOAD (LBS.)
6 MT	10791	4.62	1.63	6.57	2,050	11,000	3,500
6 MT	10792	7.37	4.38	5.85	1,300	11,000	3,500
6 MT	10793	10.12	7.13	5.85	950	11,000	3,500
6 MT	10794	12.87	9.88	5.85	750	11,000	3,500
6 MT	10795	15.62	12.63	5.85	600	11,000	3,500

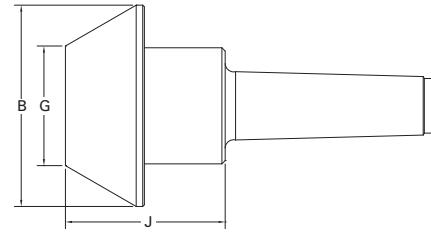

Royal "Oil Country" Big-Bore Bull Head Live Centers

TAPER	PART NUMBER	PRICE*
5 MT	10782	\$987
6 MT	10784	1,450

* Head not included. Order Separately.

Modular Heads for Royal "Oil Country" Big-Bore Bull Head Live Centers

HEAD MODEL	B	G	HEAD WEIGHT (LBS.)	PART NUMBER	PRICE
A	4.62	1.63	7	10791	\$506
B	7.37	4.38	18	10792	782
C	10.12	7.13	33	10793	1,113
D	12.87	9.88	51	10794	1,591
E	15.62	12.63	65	10795	2,773

"Oil Country" Big-Bore Bull Head Dead Centers
Also Available – See Page 103